

1

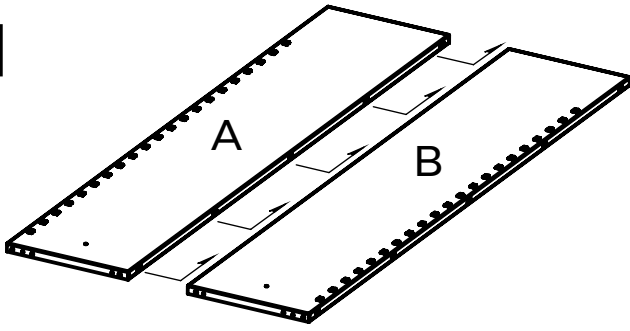

2

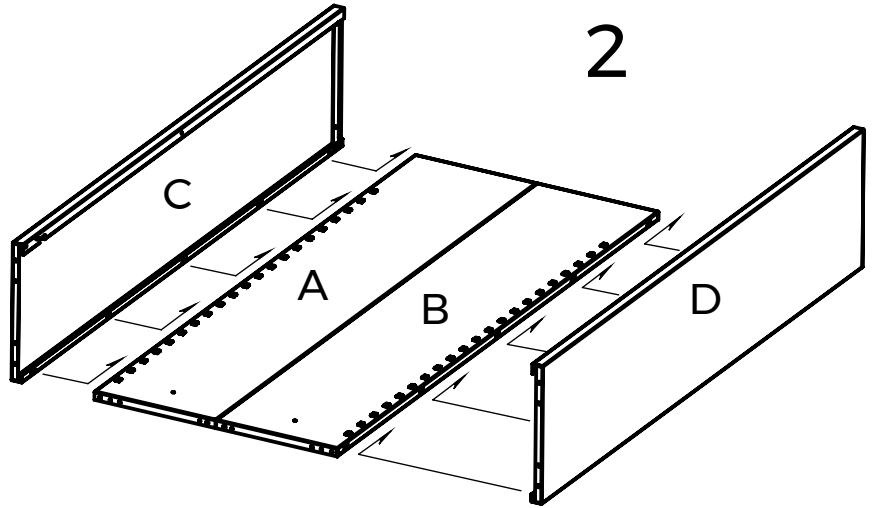

3

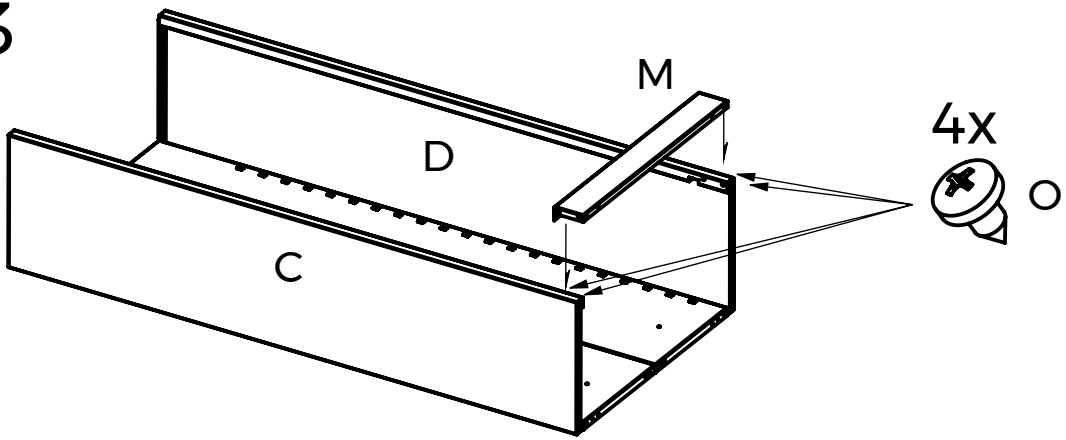

2x
○

4

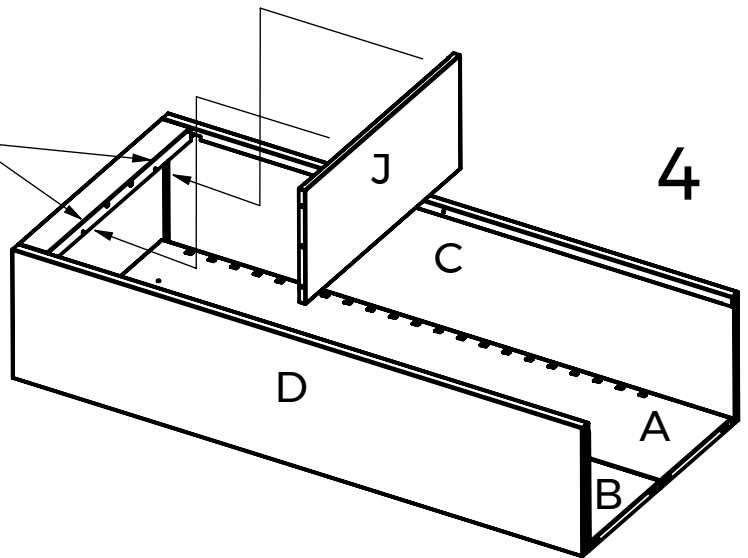

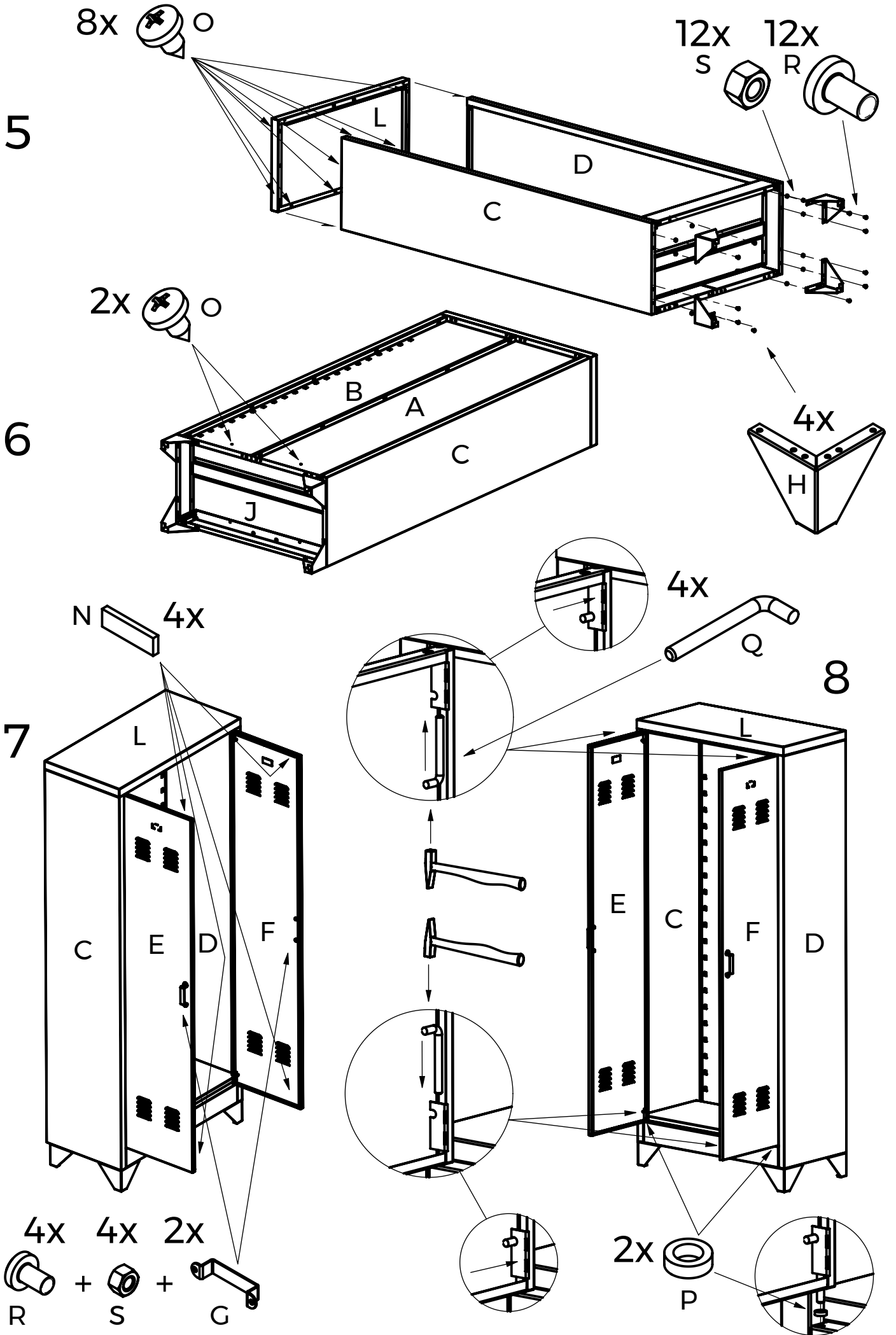

9

4X

